



**MULTI-STOREY
STEEL BUILDING
SYSTEM**



Zenith STEEL FABRICATORS LTD
DESIGN, FABRICATE & ERECT STRUCTURAL STEEL WORK
An ISO 9001:2008 Certified Company EAST AND CENTRAL AFRICA SINCE 1977

P.O. Box 18314 - 00500 NAIROBI - KENYA
TEL: +254 722 205902 / +254 720 602771 / +254 733 555281
Email: sales@zenithsteel.com

INTRODUCTION



1977



2016 (in progress)



A leading steel fabrication company and ISO 9001:2008 certified company; Zenith started its operations in 1977 as a small fabrication workshop in Kenya and was founded by Mr. Abbas T Biviji and Mr. Jayantilal Gohil. However over the years, the workshop emerged to be a magnificent company that is taking the fabrication industry by storm managing to get several jobs. The new generation intellectuals – Mr. Raheem Biviji and Mr. Kamlesh Gohil have since then expanded the businesses in Uganda, Tanzania, Zambia, Malawi, Rwanda, Southern Sudan, Ethiopia, Democratic Republic of Congo and Ghana. The company specializes in the erections of warehouses, factories, multi storey steel buildings, stadia, petrol stations, churches, water tanks, towers and bridges.



Multi Storey Buildings in steel is a trend that is fast breaking the dominance of conventional brick and mortar buildings that have for decades shaped world's skyline. While it is a recent adoption in Africa, the buildings have been used extensively in developed countries since 1940's. With today's advanced technology and innovations, the use of structural steel and concrete composite design is being applied in the construction of multi storey buildings.

Contrary to using reinforced cement concrete, in multi-storey steel building, the structure is designed and assembled in workshop and then later while on site, the steel is fixed to come up with the desired building. Buildings made of steel frame are known to take a shorter construction period because most of the materials used are designed & assembled in a workshop ready for installation. The minimum onsite labour and the short period taken by the project translate to lower costs of construction. In addition due to strength of steel, fewer columns erected when setting up the structure as steel allows for longer spans than concrete.

According to Zenith, contrary to concrete where a contractor has less control on the quality of construction, in steel building quality is assured. Indeed steel work is not mason work; steel framing requires higher technology for construction and maintenance. The technology has not been easily available in the region, and as aforementioned, Zenith Steel is the bona fide pioneer of multi-storey building technology in East Africa. Lack of new technologies in steel fabrication and construction has for a long time made development in steel work restricted to the West.

Also, one of the biggest challenges with steel-framed buildings is precision entailed on the brackets sizes, bolt holes. The capacity of CAD/CAM at design and fabrication level requires intensive training to attain. Adopting multi-storey steel construction is one way of reducing the use of timber during construction. This ensures that the environment is protected for current and future generations. Regarding perceptions that steel is prone to corrosion, Zenith assures that all precautionary measures have been put in place to ensure the safety of buildings. A special paint is applied on the steel to ensure that it is not affected by rust.

Zenith proclaims that use of steel in construction is the way to go, and declares that it will lead the way in taking the technology to all corners of the African continent and beyond.

MULTI-STOREY STEEL BUILDING SYSTEM

Multi-storey buildings in steel have been used extensively in Europe and surrounding areas since the 1940's. With today's advanced technology and latest innovations, the use of structural steel and concrete composite design is being applied in the construction of multi-storey buildings. In addition to a faster construction speed an increased economy is achieved when applying such design techniques.

COMPARISON BETWEEN CONCRETE FRAMED AND STEEL FRAMED BUILDING

CONCRETE FRAMED BUILDINGS	STEEL FRAMED BUILDINGS
<ul style="list-style-type: none">• Slower construction	<ul style="list-style-type: none">• Faster construction by up to 2 times
<ul style="list-style-type: none">• Delayed revenue on account of longer construction	<ul style="list-style-type: none">• Earlier revenue generation from completed buildings
<ul style="list-style-type: none">• Internal props / shuttering required	<ul style="list-style-type: none">• No internal props/ shuttering required
<ul style="list-style-type: none">• Higher cost of finance	<ul style="list-style-type: none">• Lower cost of finance
<ul style="list-style-type: none">• Works dependant on fair weather in many instances	<ul style="list-style-type: none">• All weather construction possible
<ul style="list-style-type: none">• Longer spans and fewer columns only possible with a heavier design	<ul style="list-style-type: none">• Longer spans and fewer columns possible with a lighter structure
<ul style="list-style-type: none">• Higher loads leads to increased foundation cost	<ul style="list-style-type: none">• Lighter building loads result in reduced foundation cost
<ul style="list-style-type: none">• Deeper beams & thicker slabs increase the nominal floor to floor heights	<ul style="list-style-type: none">• Shallower beam and slab heights can result in reduced floor to floor heights with same functionality
<ul style="list-style-type: none">• Higher overall cost	<ul style="list-style-type: none">• Lower overall cost
<ul style="list-style-type: none">• Enhanced concrete usage has a more profound impact on the environment	<ul style="list-style-type: none">• Reduced concrete use is more environmentally friendly. Steel is also more easily recyclable



CONSTRUCTION PROCEDURE

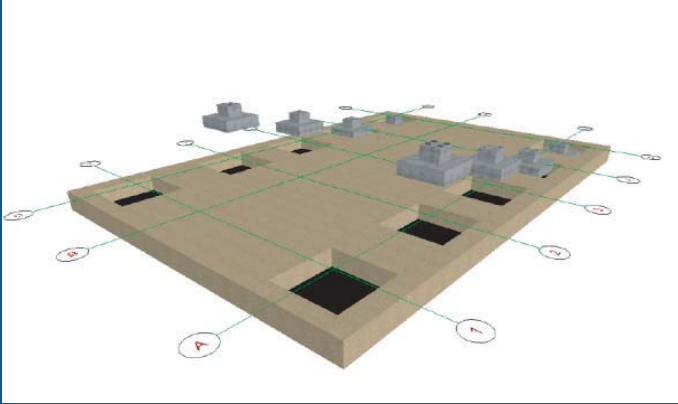

STEP 1
Construction of Foundations

STEP 2
Erection of steel Columns

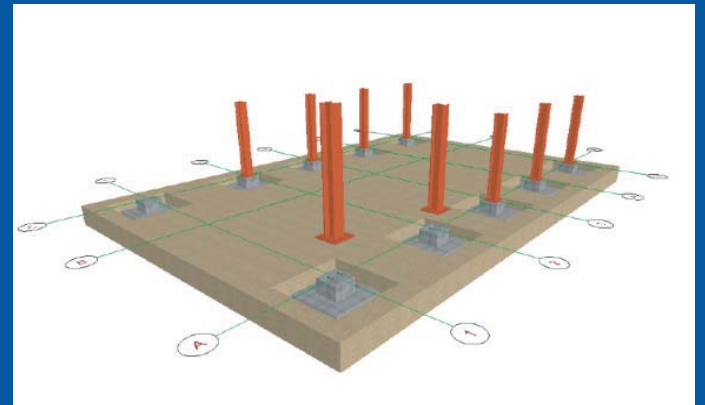

STEP 3
Erection of Primary steel beams

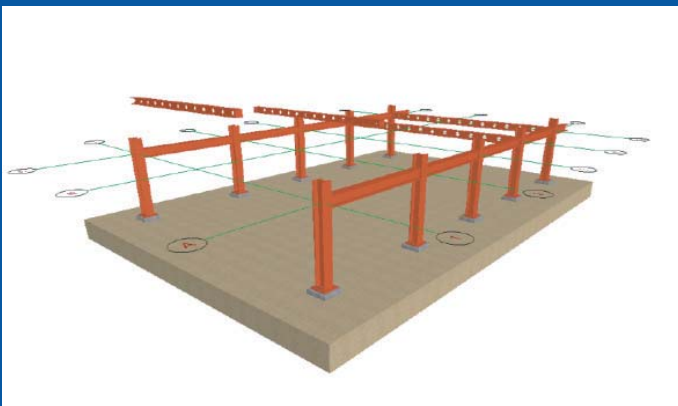

CONSTRUCTION PROCEDURE

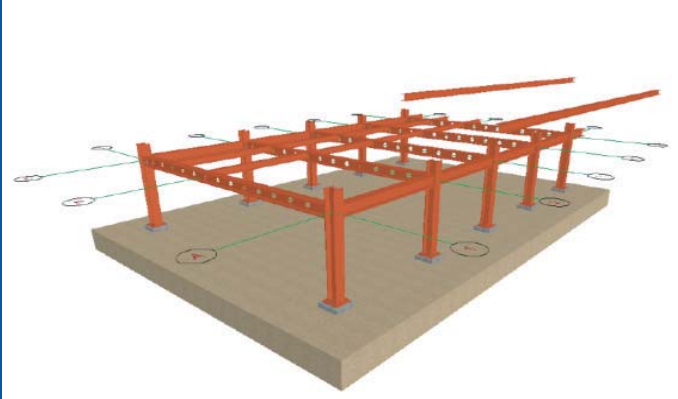

STEP 4
Erection of Secondary steel beams

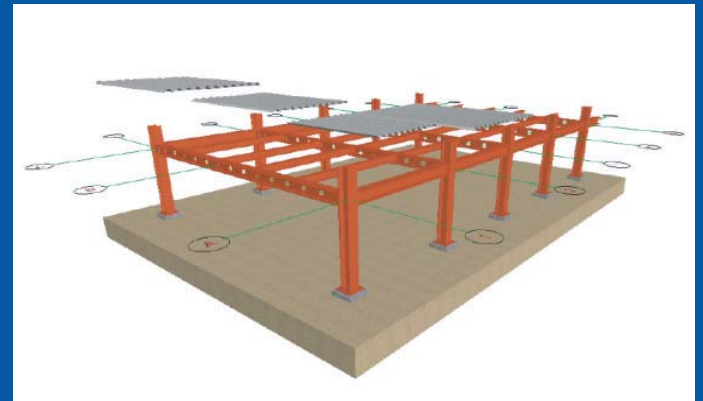

STEP 5
Fixing of decking sheets

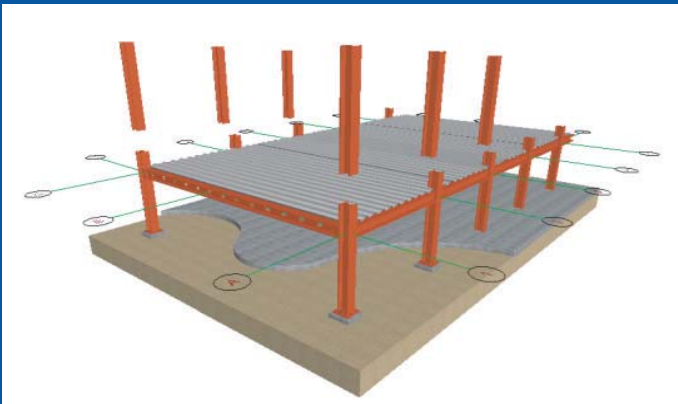

STEP 6
Fixing of upper floor columns & lay concrete on ground floor

CONSTRUCTION PROCEDURE

STEP 7

Repeat steps 3 to 5 for the upper floors
& lay concrete on floors

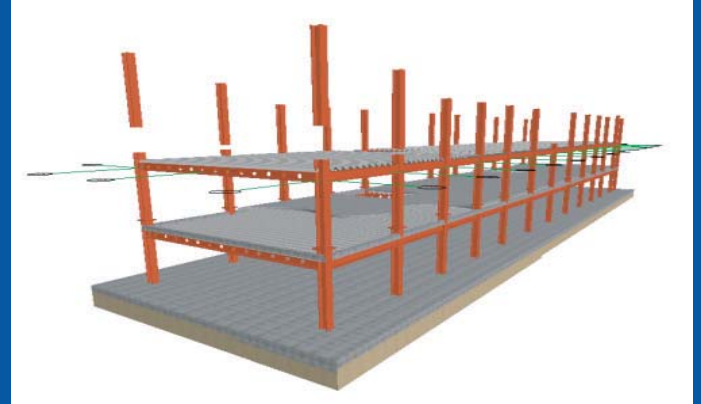

STEP 8

Lay off concrete of top most floor



STEP 9

Do all the finishing works



STEP 10

Finished building



STRUCTURAL STEELWORK SPECIFICATIONS

1. The applicable British Standards specifications to apply appropriately to design, materials and workmanship.
2. All steelwork to be cleaned and painted to specification before dispatch.
3. All Structural Steel detailing to be done using latest programs e.g Tekla and Autocad.

DECKING SHEETS

Decking sheets are fixed to the top flange of I-beams with self drilling screws. The decking sheets are designed to free span between the beams, therefore eliminating the need for props and shuttering during the casting of the concrete slab. This makes the construction method very quick and efficient since the contractor does not need to wait for the curing time of the concrete slab before moving to upper subsequent floor levels.

- A galvanized coated angular through profile is used with thickness varying from 0.5mm to 0.8mm depending upon the design load.
- The decking sheets act as permanent shutter supporting both the construction and final design loads and therefore the bottom of the shutter acts as the slab soffit finish.
- The composite steel beam and concrete deck system can be designed to accommodate loads ranging from 2.5kn/m² for light office blocks to 20Kn/m² for heavy industrial load and car park systems.

TECHNICAL SPECIFICATIONS OF DECKING SHEETS

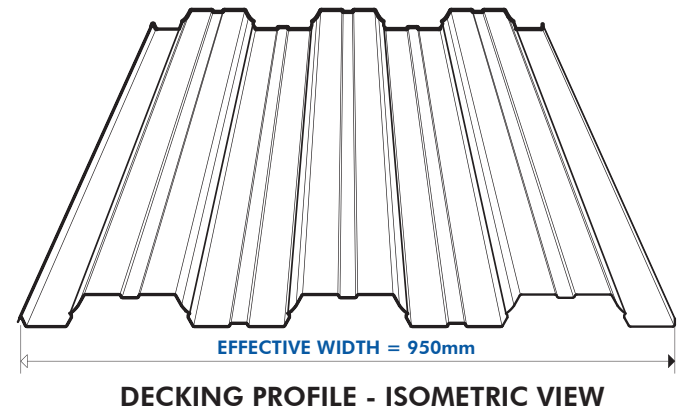

View from Underneath

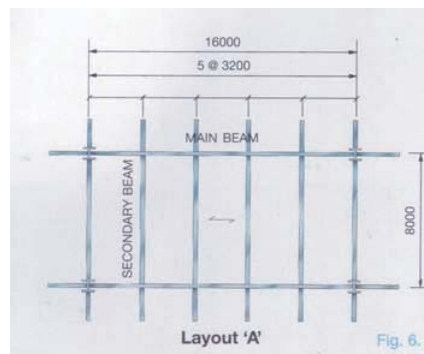

Plan on Beams

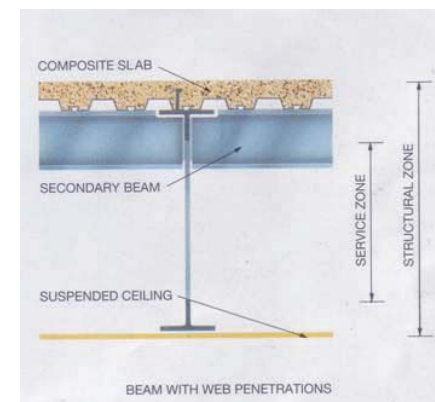

Elevation

LANDMARKS

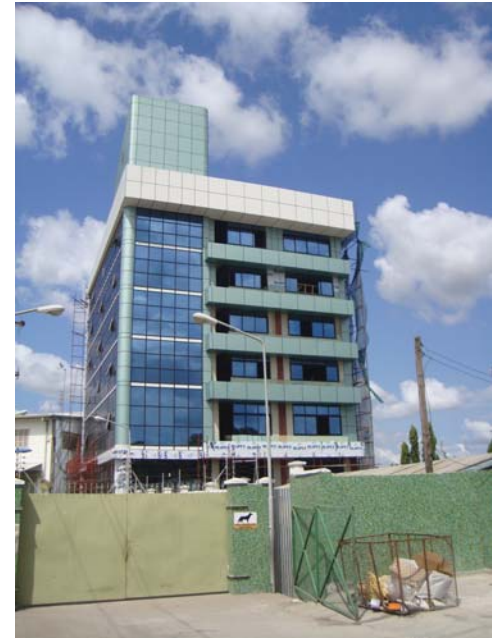

Zenith STEEL FABRICATORS LTD
DESIGN, FABRICATE & ERECT STRUCTURAL STEEL WORK
An ISO 9001:2008 Certified Company EAST AND CENTRAL AFRICA SINCE 1977

P.O. Box 18314 - 00500 NAIROBI - KENYA
TEL: +254 722 205902 / +254 720 602771 / +254 733 555281
Email: sales@zenithsteel.com